

False fences, saddles and tunnel guards

Peter Sefton shows us how to use false fences and tunnel guards

When the request came through for me to write an article on false fences, saddles and tunnel guards, Sarah thought it was a request from Horse and Hound to cover the Badminton Horse Trials, which is far from my area of expertise. I'm pleased to say the request was for an article about setting up machines for both safe and productive wood machining, which is an area much closer to home.

Peter Sefton

Peter teaches good machine practices on his long and three-day wood machining courses. For more information visit www.peterseftonfurnitureschool.com.

Safety first

Many makers that have been around for a few years would have been trained on machines using the 1974 regs and remember scary stories of old French head and slotted collars on spindle moulders and how dangerous they were. Nowadays I'm sure those types of cutter blocks are quite rightly things of the past as they have been superseded by chip limiting cutter blocks. The 1998 PUWER regs and ACoP superseded the 1974 regs, but many woodworkers haven't taken the changes to heart. Hopefully this article will highlight the benefits of using appropriate guards.

The use of false fences on spindle moulders has been a legal requirement for many years but most spindle manufacturers have made little or no provision for their fixing, and many woodworkers have been unaware of them or might even have chosen not to use them, leaving them vulnerable to danger or even prosecution if they run a commercial workshop. I find my spindle moulder the most versatile and adaptable

machine in my workshop, but as with all machines it must be treated with care and respect. I would no more use my spindle without a false fence and adequate guarding, than I would drive my car without using my seat belt. Some may still say guards are an inconvenience that slow you down but as with all these things, you would be very thankful you took time to make yourself safe, should the worst happen.

Here I show some of the setting up procedures for false fences and tunnel guards on the spindle and the principles can be adapted for other commonly used woodworking machines. This not only makes their use legally compliant but improves dust extraction efficiency, prevents timber from dropping onto cutters and entering the fence body, and gives increased work support thus reducing tearout or chip breaking (which ultimately saves us the tedium of the extra sanding involved to remove unnecessary machining marks due to chatter).

► Correct selection



I use an MDF baseboard when the cutter block diameter does not suit standard table rings

The first consideration when doing spindle work must be the correct selection of cutter blocks and spindle speed setting. The spindle table must be enclosed as much as possible by the insertion of table rings to stop the possibility of components dropping into the hole in the table. If this cannot be achieved, use of a false table is required particularly when moulding small sections, to give them adequate support and stop them falling into the table. I usually use MDF as a baseboard with a segment cut-out of it to suit the diameter of the cutter block.

MDF baseboards can also be used on the table or bandsaw to stop our timber falling and becoming trapped in the mouthpiece.

Closing the gap

For closing the gap between the in-feed and out-feed fences on the spindle, we have a couple of options. On my Hammer F3 I can set the bars that fix between the fences and span the gap, thus stopping timber dipping into the cutter block which can be the cause of snatching and kickback (ejecting the timber) potentially causing

serious injury. The setting of the bars is a relatively quick operation to do and has the additional benefit of avoiding the breaking through of a false fence with the cutter block.

The more traditional option is to fix a timber faceplate to the spindle's metal fences and then fix MDF (or similar) that spans the two fences, creating a false fence.



I use Hammer safety bars on my machine, which are quick and safe to set up plus there is no loss in the usable diameter of the tooling

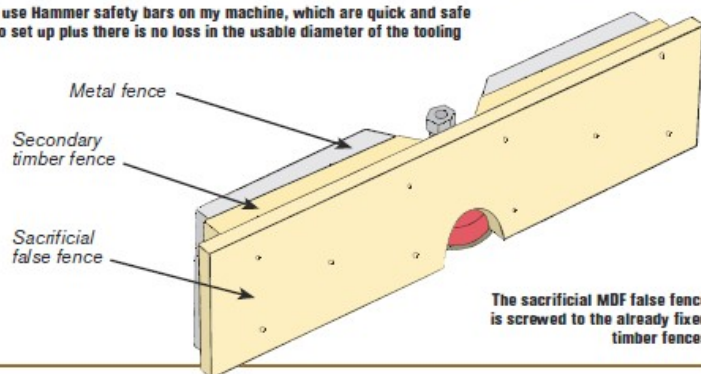

The sacrificial MDF false fence is screwed to the already fixed timber fences

Fence plates

I created a pair of poplar timber fence plates, which are permanently screwed onto the in-feed and out-feed spindle fences. This now allows me to screw sacrificial MDF false fences to them, as and when required. Traditionally these would have been pinned on but the thought of somebody hitting my accurately set spindle moulder with a hammer, fills me with horror.

The false fence approach is more time consuming to set up than bars and it does require the cutter block to be broken through the false fence with the cutter block working at full speed. So, care must be taken when this is being done, as this process carries risks of its own.

Shaw guards

On spindles, Shaw guards must be in position to protect the user, but these guards must be positioned so that they cannot come into contact with the revolving cutters, as the false fence is moved backwards onto the revolving cutter block.

The advantage of having an MDF false fence is that you can attach workshop-made saddles, tunnel

guards or Shaw guards to suit particular situations, which I'll go on to talk about later.

When I make a new false fence I sand it smooth and use candle wax to enable the work piece to glide along the fence. I use the back of abrasive paper wrapped around a cork block to rub and melt the wax and burnish the fence surface.



A saddle has been screwed to the false fence. Now we need to position the Shaw guards and break through the false fence



A swirl of wax is burnished to lubricate the false fence

Break on through



The height of the spindle block is set 1mm higher than its finished position, before attaching the false fence



A pre-set pair of wooden blocks are behind the fence to act as a stop when the fence is in the correct position

To break through a false fence, the procedure I use is as follows -

Isolate the machine before making any adjustments

1. Fit the block onto shaft and tighten.
2. Set the block height with either a rule measuring to a specific point, a setting gauge or in my case Japanese square.
3. Check the fences are parallel and in line.
4. If your fences are adjustable, move them together to suit the cutter

block diameter. Screw the false fence board onto the wooden fences. It is good practice to have the face board up to the full height of the fence, to prevent any open space when working and a cover piece over the top.

5. Set up the Shaw guards so they cannot come into contact with the cutter block but do protect the user.
6. Spin the block by hand, then turn the power on and pump start the machine and if it's safe, slowly

feed the fence into the full speed revolving block, in a controlled manner. Feed back until the cutter protrudes approximately 1mm more than the required depth of cut by sighting up from above or against pre-set stops.

Turn off/isolate the machine and bring the fence forward by 1mm to stop the cutters rubbing on the face board when started up. This will prevent blunting and reduce the noise level.

Safe operations

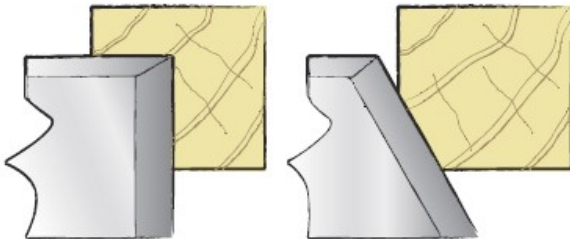

The safest position for cutters in general use

Wherever possible your timber should be over the cutter. This will allow the timber to act as a guard, thereby enclosing the cutter.

One exception to the rule is when cutting fielded panels. By working the cutter above the timber, the panel will be a constant thickness, even if the material varies in thickness.

Tunnel guards and saddles

Now that we have minimised exposure of the cutter to the user, we must consider guarding that exposed cutter and giving our timber adequate support through use of a Shaw guard or tunnel guard.

Our guards must provide pressure to the top and front of the timber to prevent it from moving away from the fence or

bed, but still allow for fluid movement so that feeding is not difficult.

To feed all the way through a Shaw guard, a push stick can be used but this must not be allowed to come into contact with the cutter block, as it can snatch and be thrown back. Avoid pulling the timber from the out-feed end and never push with bare hands past the cutting head. Use a spare piece of timber of the same section.

Machine deep rebates with the addition of a saddle to prevent the work piece twisting into the cutter block in the final 50mm or so.

I also use workshop-made concertina and feather guards when the supplied Shaw guards don't suit the timber section.

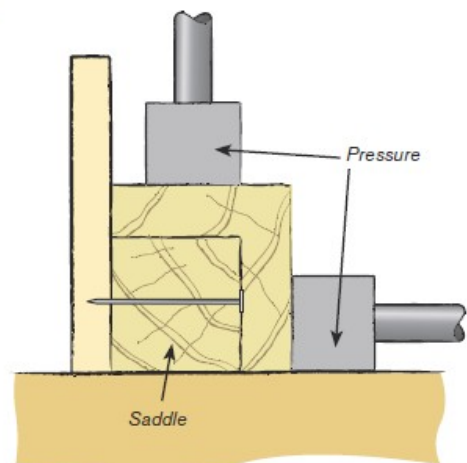
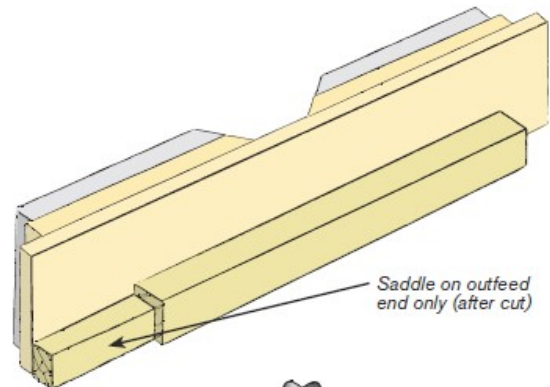

The Shaw guards form a tunnel over the rebate block and the saddle supports the timber after being cut

PROJECTS & TECHNIQUES

Making the most of your spindle moulder

► Safe operations

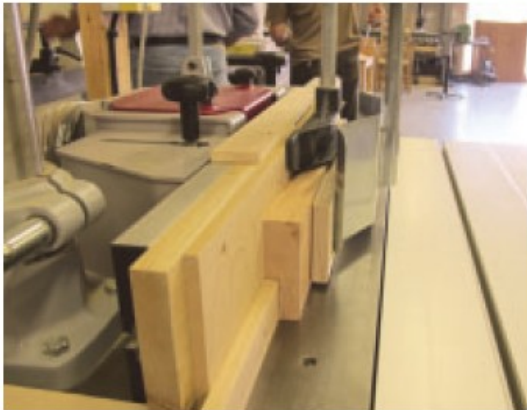

I have adapted my front Shaw guard with the addition of a piece of waxed plywood to give even pressure



Workshop-made concertina guards add even more flexibility to guarding

Power feed units

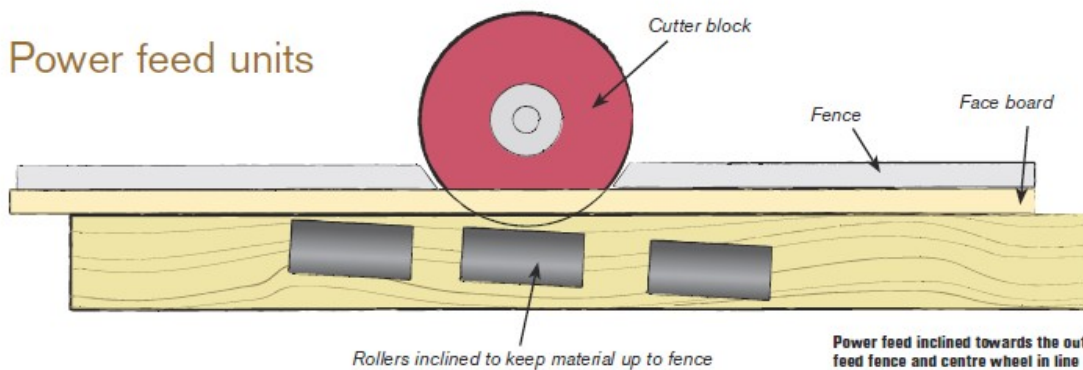

Power feed inclined towards the out-feed fence and centre wheel in line with the centre of the cutter block

However careful a user is when feeding, there can be times when the surface finish is affected by starts and stops or differences in manual feed speed. Continuous controlled feeding is best achieved by means of a power feed unit.

Power feeds increase production and cut down on the fatigue you may experience. Each roller is spring-loaded and although the unit setting takes some getting used to, you'll wonder how you managed without one. Adjustments can be made to position the rollers to suit almost any type of work including curved work.

The power feed unit can be set up to either pass timber through the machine against the table, or vertically against the fence. On the better units, you can vary the speed in both forward and reverse and most importantly, it is safer and easier than feeding by hand.

I try and keep the middle roller in line with the cutting head. This allows you to apply both direct pressure while cutting, as well as the work being held firm both before and after

cutting. Rollers are slightly inclined towards the outfeed fence to keep the timber pulling tight up to the fence throughout the process. I tend to use my power feed unit for 95% of my spindle work and sometimes use an additional Shaw guard for extra timber support and find this the best solution

to most of my cutting needs.

I love the quality finish that my spindle moulder produces and hope that other woodworkers can see that with the variations of guarding described, and due consideration to safe use, it can be a real asset to your workshop. *F&C*



The power feed being used in conjunction with the Shaw guard